

## Quick Ship Walk-In Modular Cleanroom



The **Quick Ship Walk-in Modular Cleanroom** provides an economical solution for creating a clean air positive-pressure environment that ships in 5 business days. This system meets up to *Static ISO Class 7 Standards*, which require a maximum of 2,930 particles per cubic foot for particles larger than 5 microns and 352,000 particles per cubic foot for particles larger than 0.5 microns, with at least 60 air changes per hour. The **Quick Ship Walk-in Modular Cleanroom** offers a sturdy enclosure constructed of a heavy-duty steel frame, ¼” twin wall polycarbonate walls, and a door designed in-house to optimize downward laminar flow.

The **Quick Ship Walk-in Modular Cleanroom** utilizes 1-2 fan filter units (FFU) to draw ambient air into the filtration chamber, filter out airborne contaminants such as dust, and release the cleansed air into the enclosed workspace. The FFU(s) use a **HEPA filter** (up to 99.97% efficiency down to 0.3 microns) and an optional pre-filter. Each FFU provides up to 650 CFM at max speed. The FFU uses an EC motor offering energy efficiency and reduced noise levels. The system allows for room-side service and a PAO port for testing. The unit’s control panel allows the operator to select local or remote control using a switch on the control panel. An optional remote control provides a variable speed controller for the FFU(s). Also included are 2 LED light panels to help improve visibility inside the enclosure. The **Quick Ship Walk-in Modular Cleanroom** features simple installation and can be relocated easily. The system bolts to the floor to help maintain cleanroom efficiency.

*Custom Walk-in Cleanrooms are available with a 4-5-week lead time after design approval. Please consult your Sentry Air Application Specialist for more information.*



*Quick Ship Walk-in Modular Cleanroom with 2 Fan Filter Units*

### Product Features

- Meets up to Static ISO Class 7 Cleanroom
- Heavy-duty steel frame and 1/4” twinwall polycarbonate walls
- 1 or 2 room-side serviceable Fan Filter Units
- 2 LED light panels
- Optional remote control

### Typical Applications

- Pharmaceutical compounding
- Electronics and semiconductors
- Aerospace product development
- Inspection and weighing stations
- Medical device production
- Cosmetics production
- Automotive manufacturing
- Temporary cleanroom
- Optics assembly
- Robotics
- Food packaging



21221 FM 529 Rd, Cypress, TX 77433  
1.800.799.4609 • sales@sentryair.com

[www.sentryair.com](http://www.sentryair.com)

## Product Specifications



### FAN FILTER UNIT

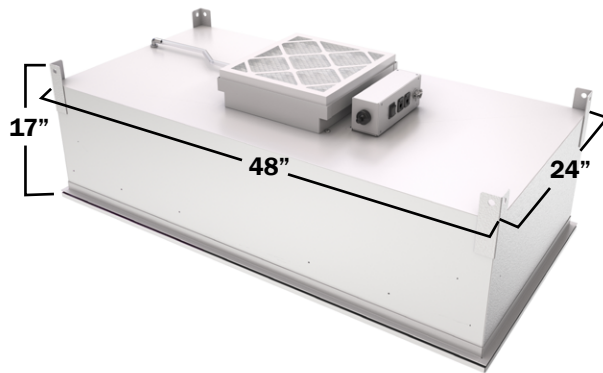

Dimensions are approximate.

### WALK-IN MODULAR CLEANROOM

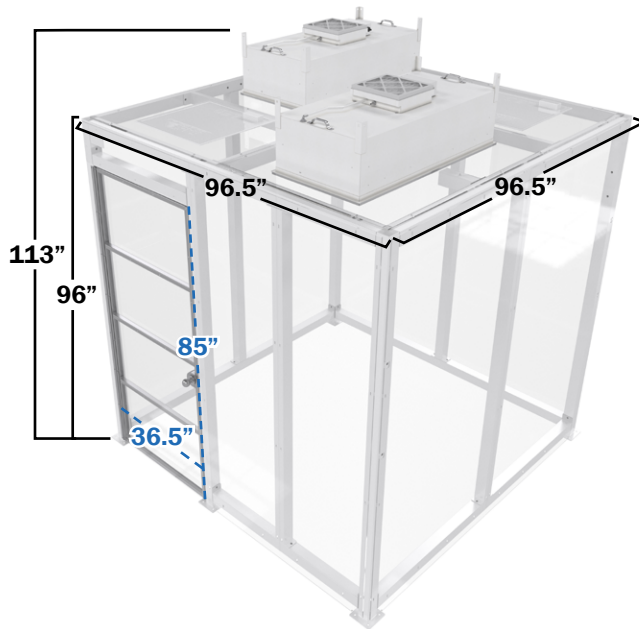

Approximate outer dimensions are shown.



21221 FM 529 Rd  
Cypress, TX 77433  
1.800.799.4609  
sales@sentryair.com

[www.sentryair.com](http://www.sentryair.com)

Fan Filter Unit Specifications	
<b>Cabinet Material</b>	Powder coated carbon steel
<b>Dimensions</b>	48" L x 24" D x 17" H
<b>Weight</b>	90 lbs
<b>Airflow</b>	650 CFM (max speed)
<b>Service-side</b>	Room-side Serviceable
<b>Motor</b>	EC motor
<b>Electrical</b>	Hardwired by an electrician 120/1/60, 2.2 amps <b>Max power input: 175 W</b>
<b>Filter Type</b>	<b>HEPA</b> [up to 99.97% efficiency on particles 0.3 microns and larger]
<b>Sound Level</b>	65 dba when running at the speed to meet ISO 7
Walk-in Modular Cleanroom Specifications	
<b>Dimensions (W x D x H)</b>	<b>Full:</b> 96.5" x 96.5" x 113" <b>Outer:</b> 96.5" x 96.5" x 96" <b>Interior:</b> 90" x 90" x 93"
<b>Door Dimensions</b>	<b>Width:</b> 36.5" <b>Height:</b> 85"
<b>Frame Material</b>	3" x 3" powder-coated steel structural tubing
<b>Wall Material</b>	1/4" clear twinwall polycarbonate
<b>Weight</b>	800 - 900 lbs
<b>ISO Rating</b>	up to Static ISO Class 7
<b>LED Lights</b>	2' x 2' LED Even-Glow 4400 lumens, 40 W, 0.33 A
<b>Warranty</b>	Limited one-year warranty from date of shipment on defects due to materials or workmanship.